



SEPARATION TECHNOLOGY PRODUCTION OF INSTANT COFFEE

**Yield-based coffee extraction
plus coffee oil extraction**

 **Flottweg**

Engineered For Your Success



CONTENTS

Highest quality and yield for your instant products	Page 02
Perfecting proven processes	Page 04
Overview of instant coffee production applications	Page 05
Clarification of thin extract and thick extract with the Flottweg separator	Page 06
Recovery of valuable raw material with the Flottweg decanter	Page 08
Extraction of coffee oil with the Flottweg belt press and Flottweg Tricanter®	Page 10
Treating and reducing process wastewater	Page 13
High yields even with small production volumes	Page 14
Optimizing processes and procedures	Page 15
Flottweg quality and service	Page 16





HIGHEST QUALITY AND YIELD FOR YOUR INSTANT PRODUCTS

Instant coffee has long since evolved from its niche existence as a coffee substitute and has become a lifestyle product. Countless varieties, flavors, and portion sizes make up this highly attractive and still expanding segment of the coffee market, which brings in tens of billions of euros in Europe alone.

However, as its popularity increases, so do the requirements: Consumers don't just want to be surprised with new recipes, they also want to be impressed by their quality. Instant coffee producers are faced with the challenge of meeting these demands while making their production methods more and more efficient at the same time. Industrial centrifuges are a great help to manufacturers in this, as they separate the insoluble components of the coffee beans from the valuable coffee extract. This increases the purity and quality of the finished instant product and provides you with the following benefits, among others:

- Efficient clarification of thin extract and thick extract
- Valuable raw material instead of waste: best possible use of, e.g., coffee grounds
- Maximum quality for final instant product with maximum yield at the same time
- Extract valuable coffee oil



Flottweg is the chosen partner for numerous companies that produce high-quality, flavorful instant coffee on an industrial scale.

We support these producers with our separators, decanters, and belt presses. These machines help to increase the quality and purity of the finished (instant) product. In addition, valuable raw materials can be recovered in secondary flows.

Flottweg projects stand for absolute customer focus, maximum efficiency, and planning and implementation under the label "Made in Germany". And they create processes that provide you with a greater overall yield and profitability.

We invite you to learn more about our instant coffee production applications: Learn what 'Engineered For Your Success' can mean for you and for your company!



SUCCESS IS DRIVING KNOWN PROCESSES TO PERFECTION

The basic principles of producing instant coffee are well-known and proven. Flottweg makes no changes to the basic procedure – we deliver powerful key technologies to support your solid-liquid separation processes. The result: maximum yield, absolute quality, and added value.

Our portfolio for instant coffee production

- Flottweg separators for clarifying thin coffee extract
- Flottweg separators for clarifying thick coffee extract
- Flottweg decanters for processing the solids discharged by the separator
- Flottweg belt press for dewatering coffee grounds
- Flottweg wastewater decanters for treating process wastewater

Production advantages

- Can be connected to process control systems at any time
- Easy to integrate into existing processes
- “Made in Germany” engineering and products

Economic

- Extract residual extract from coffee grounds
- Extract coffee oil from press water

Ecological

- Use solids for thermal recycling
- Save on disposal costs thanks to reduced COD effluent values



Overview of instant coffee production applications

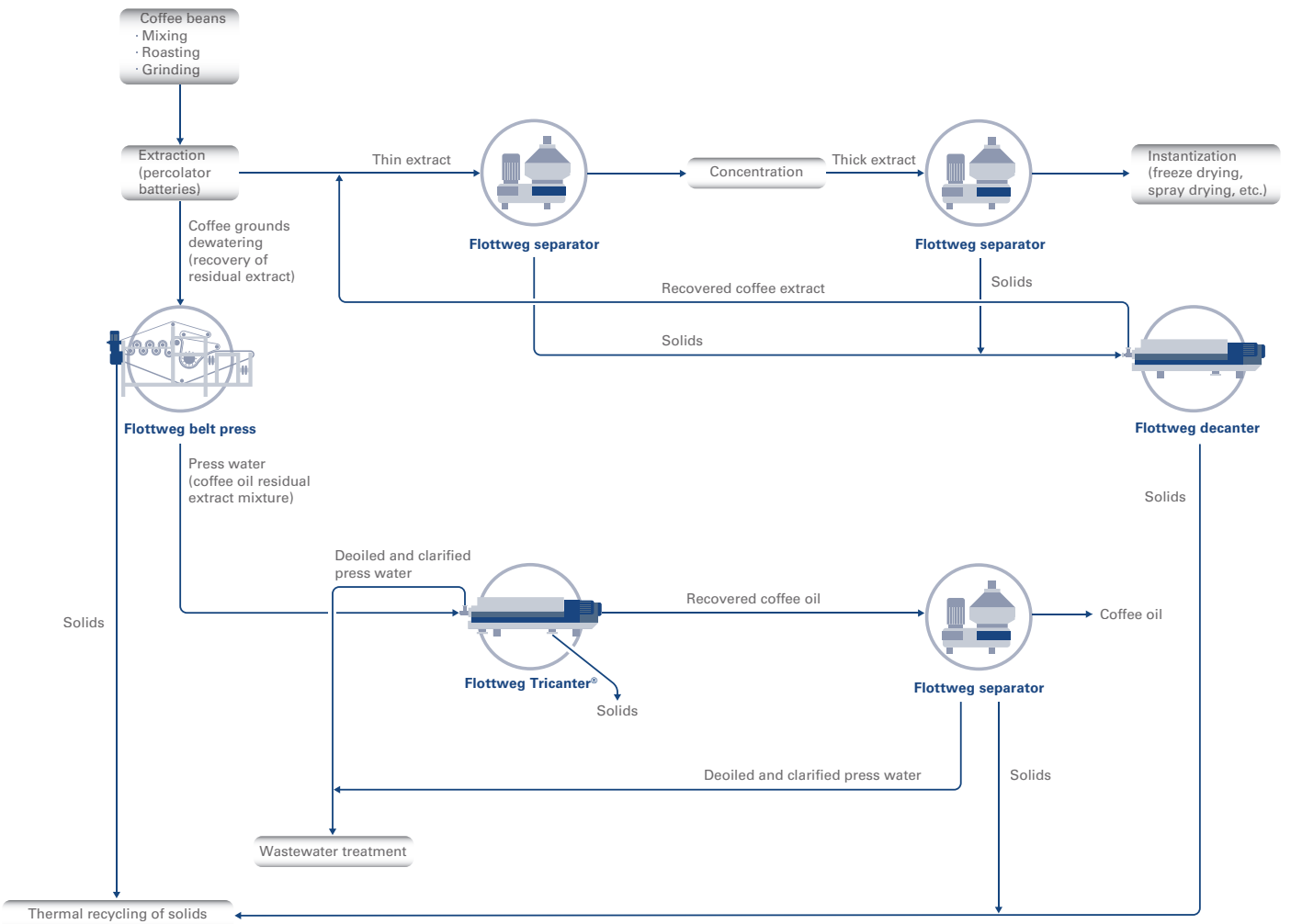

® = registered trademark in various countries.



CLARIFICATION OF THIN EXTRACT AND THICK EXTRACT ...

Soluble coffee or instant coffee blends are obtained by extracting roasted coffee. After blending, roasting, and milling, the coffee is extracted under pressure. The resulting coffee extract solution contains some insoluble components. By removing these components, consumers can enjoy their coffee without any residue in the cup. Flottweg separators are used at precisely this point in the production process: These separators remove all visible particles, thus improving the quality of the finished product, i.e., its instant properties.

Thanks to these separators' flexible speed settings, the separation resolution can be adapted to customer requirements. This ensures that the final product retains the desired flavors. Depending on the number of separators used, the yield can be further improved in this process step. The solids discharged by the separator still contain traces of the extract, which can be recovered by a downstream decanter and returned to the process, depending on the capacity of the overall system. This increases the overall yield.

Results

- Improved instant properties
- Higher product quality
- Preservation of flavor carriers
- Solids prepared for downstream Flottweg decanter

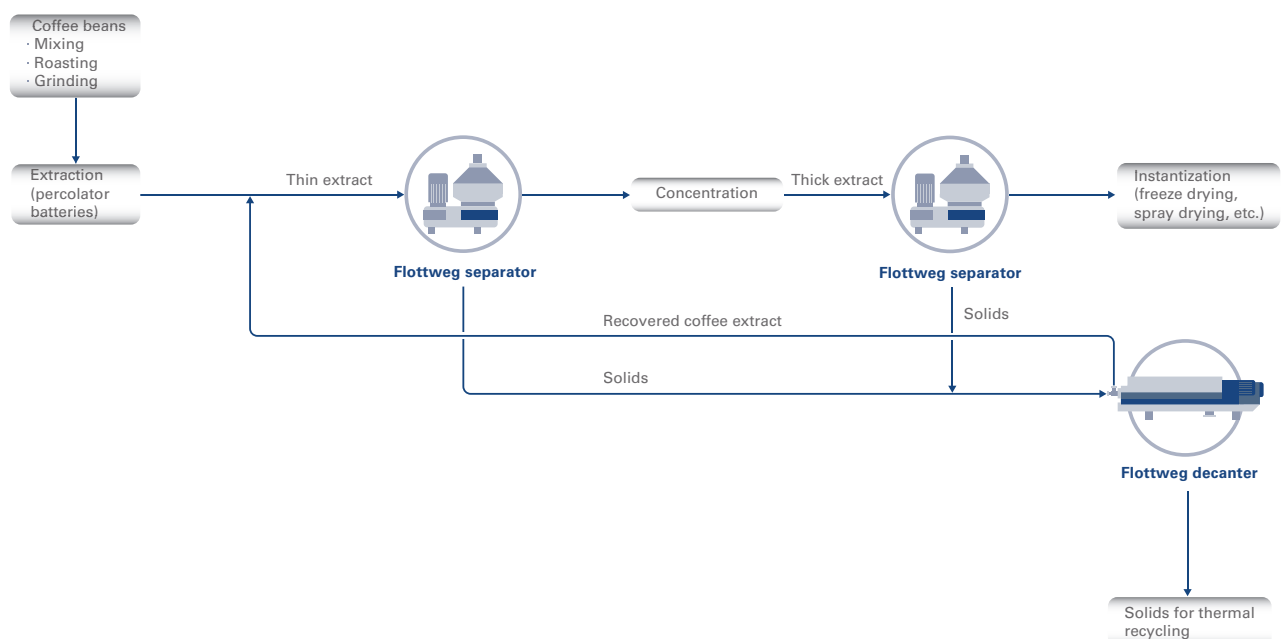

... WITH THE FLOTTWEG SEPARATOR

The insoluble components of coffee extract have a notably viscous, sticky consistency. The quality can vary greatly depending on the blend ratio for the coffee varieties used (proportion of Robusta/Arabica). During separation, these components settle in the solids space of the separator bowl. The challenge here is to safely discharge the separated solids from the bowl during emptying. The solution: To ensure the maximum extract yield and safe operation of the separator, Flottweg separators feature a variable drum emptying system.

With the Flottweg Soft Shot® system, the drum opening times can be configured as necessary. This gives the solids enough time to separate from the solids space. What makes Soft Shot® special: Additional hot water can be fed into the open bowl during the emptying sequence. This keeps the solids space and disk pack perfectly clean. We also refer to this “flush discharge” as “total flush discharge.” It does not matter what type of output is being processed: Soft Shot® also allows for any combination of partial and full emptying. This ensures a safe process and the best possible yield.

Results

- Maximum overall yield
- Quick and easy cleaning
- Improved process reliability



The Flottweg Soft Shot® system

- Any combination of partial and full emptying, which means flexible, custom adaptation to the customer's existing process for maximum product yield
- Total flush discharge for the removal of tough extract residue, reliable emptying, and maximum cleaning
- Material-safe solids discharge that emits almost no sound



The separator bowl

Maintenance-friendly

- Compact and robust design
- Easy to assemble and disassemble

Low operating costs

- Fewer components and seals
- “Made in Germany” quality



The wear protection

- High wear resistance
- Longer service life of separator
- Economical, since only wear parts will need to be replaced

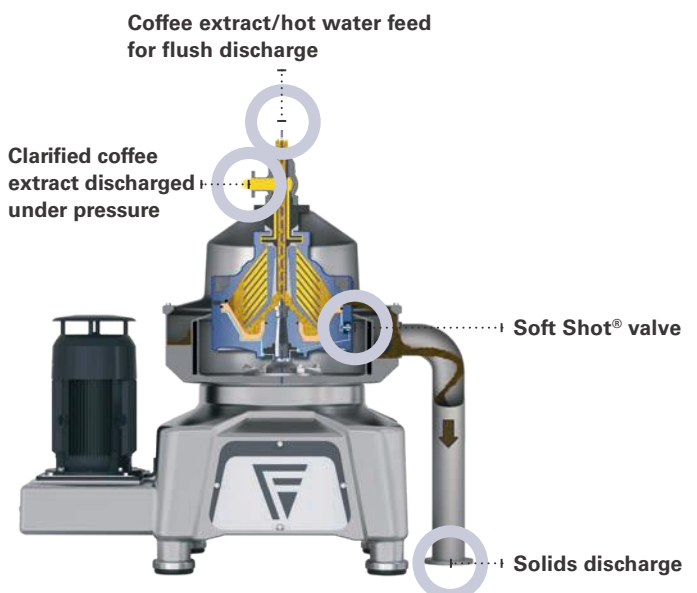

RECOVERY OF VALUABLE RAW MATERIALS ...

A significant quantity of solids is discharged depending on the type of separator, number of clarifiers used, and processing method. This solid material contains valuable coffee extract. As such, it can be worthwhile to further process the solids-extract mixture. To do so, it is first mixed with hot water. A decanter then efficiently separates the solids from this mixture. The resulting very dry solid (up to 50% dry matter content) can be thermally recycled directly. The extract obtained is then returned to the process. This minimizes product losses.

Results

- Minimal product losses
- Increased efficiency
- Lowest residual moisture for improved thermal recycling

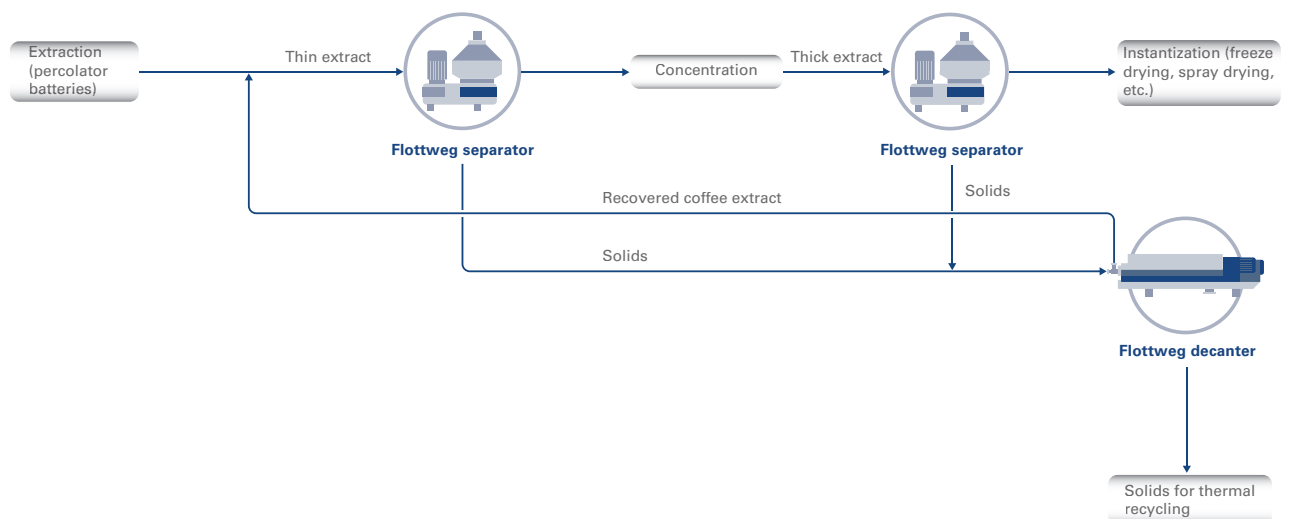

... WITH THE FLOTTWEG DEKANTER



Flottweg Simp Drive®

- Outstanding recovery rate for coffee extract due to consistently high dry matter content in separated solids
- High yield even under fluctuating process conditions thanks to fully automatic adjustment of operating parameters
- High added value with improvement of overall coffee extract yield
- No blocking of dekanter bowl



Flottweg impeller

- Closed discharge of concentrate under pressure, preventing the formation of foam
- Liquid discharged under pressure, avoiding the customary need for a conveying pump
- Pond depth can be adjusted during operation, ensuring optimal adaptation to changing conditions (product property in feed)
- Optional: Can be automated



Flottweg oil-air lubrication system

Our centrifuges can be equipped with an oil-air lubrication system upon request. This system utilizes minimal lubrication, with oil droplets being transported to the bearing points with the aid of compressed air. In addition, the Flottweg oil-air lubrication system is monitored continuously to ensure its operational reliability.

- Constant lubrication and cooling of rotor bearings
- No oil change necessary, reducing oil consumption to a minimum
- Slight overpressure at lubrication points prevents the penetration of gases or aerosols into the rotor bearings, thus extending their service life

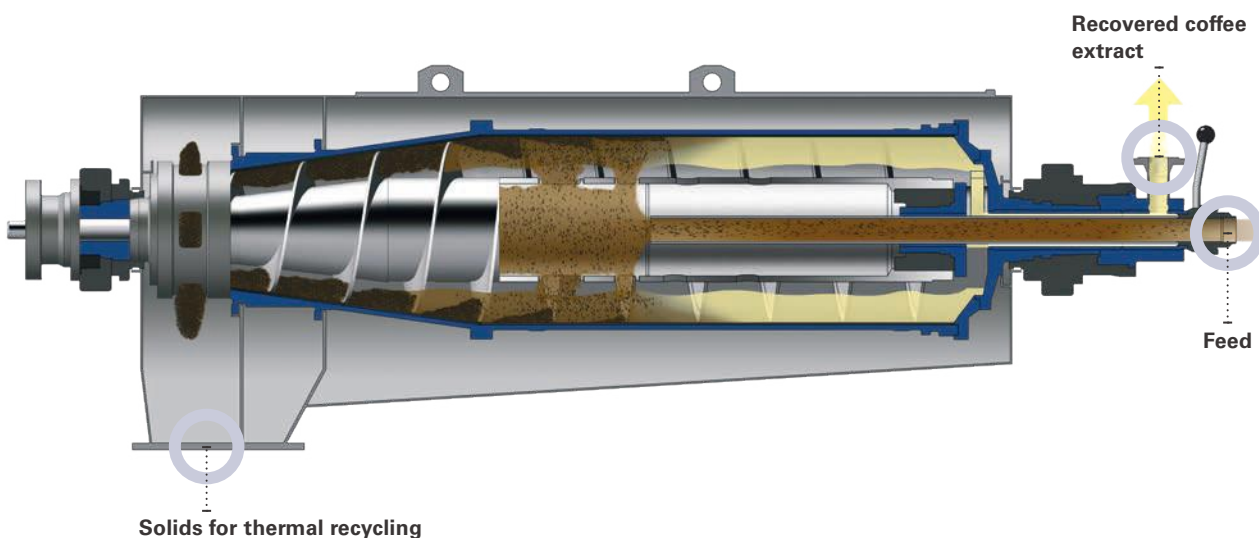

COFFEE OIL EXTRACTION ...

The residue from the percolators or extractors, the so-called coffee grounds, contains different amounts of valuable coffee oil depending on the overall process. This oil can be obtained through a two-stage process using Flottweg machines: First the coffee grounds are pressed, then the press water is separated into its component parts.

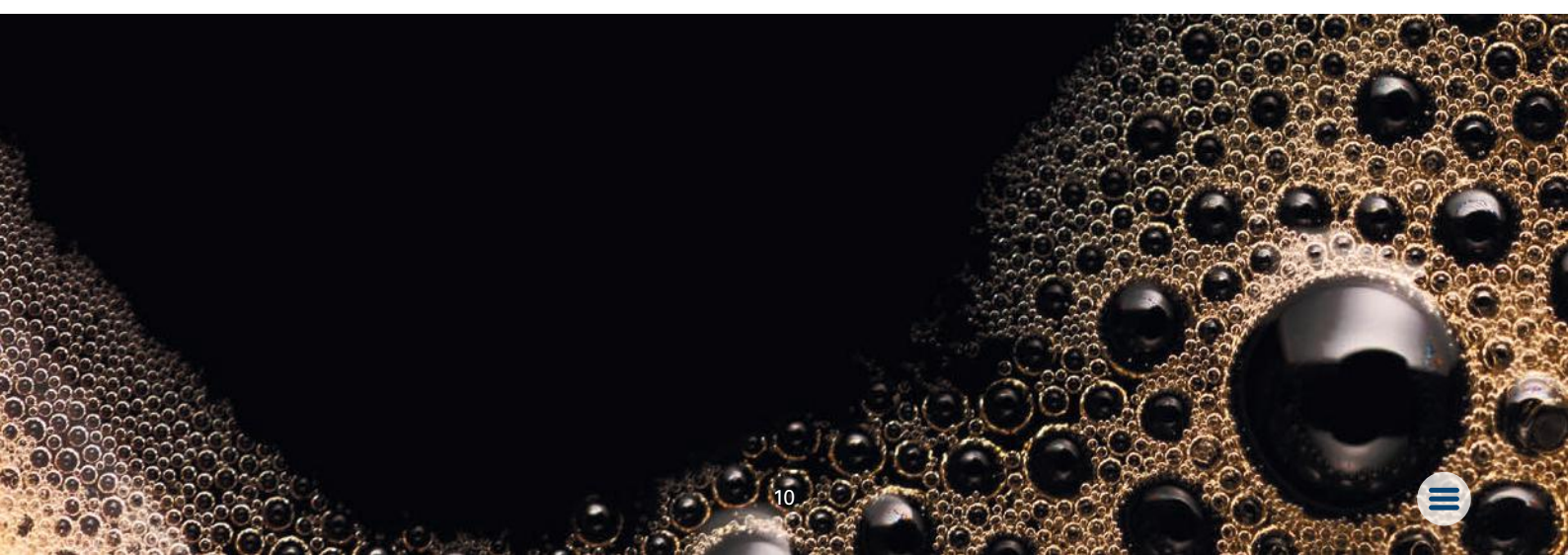
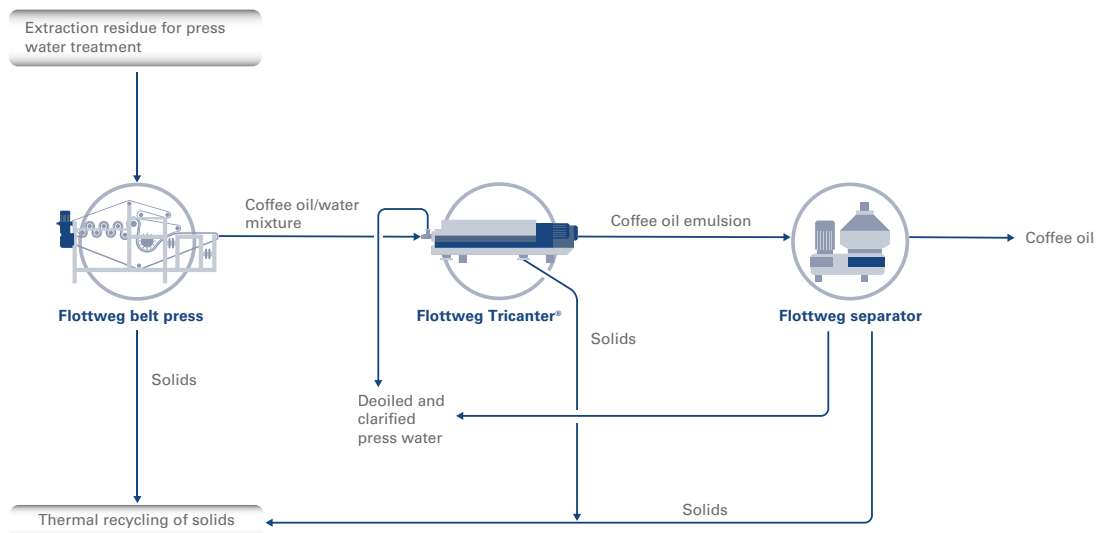

... VIA PRESSING COFFEE GROUNDS ...

The Flottweg belt press

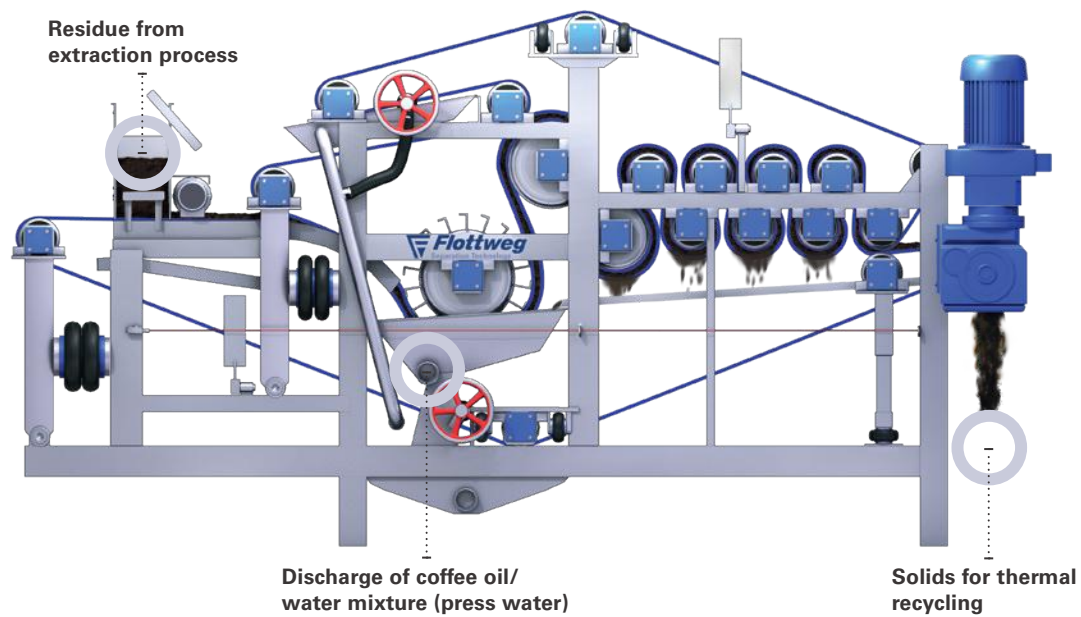

Benefits of the Flottweg belt press

- Excellent thermal recycling for coffee grounds due to high dry matter content downstream of belt press
- Low degree of solids penetration through filter belts, greater efficiency in subsequent coffee oil preparation
- Highly durable stainless steel
- Straightforward design and easy access for cleaning and operation
- Pneumatic belt control system for simple, reliable operation

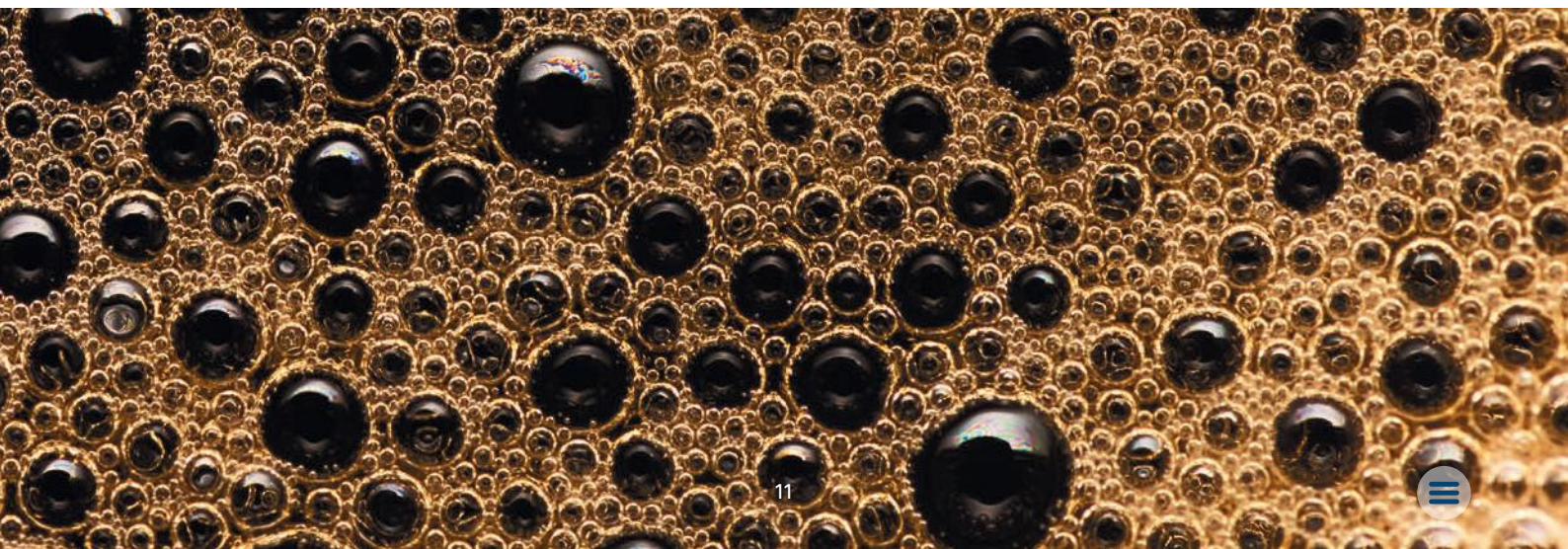

... AND DEOILING PRESS WATER

The Flottweg Tricanter®

The three phases contained in the press water can be separated in one process step with the Flottweg Tricanter®. Residual solids are removed and can also be recycled thermally. The coffee oil, a valuable raw material, is separated from the residual extract. Depending on the quantity and purity of the oil obtained in this way, a separator can also be connected downstream to polish the oil phase. If residual extract is to be recovered, the deoiled and clarified press water can be fed back into the main product flow.



COMPENSATE FOR VARIABLE FEED CONCENTRATIONS:
OPTIMUM SEPARATION RESULTS WITH THE FLOTTWEG TRICANTER®

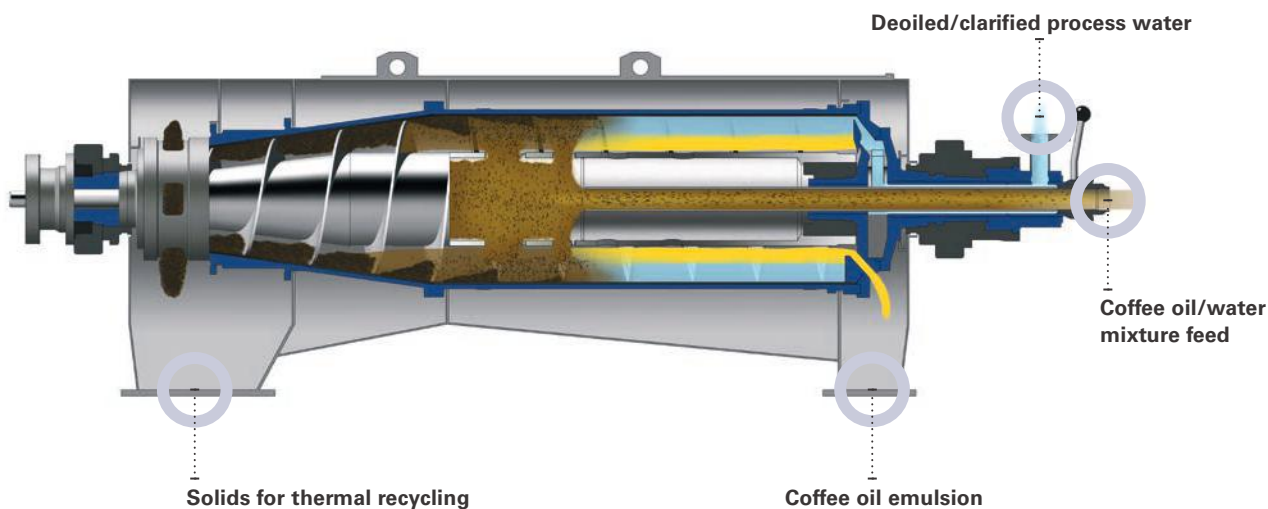

Benefits of the Flottweg Tricanter®

- Optimum separation results due to easy adaptation of the separation zones, even during operation
- Efficient coffee oil yield
- Deoiled process water discharged under pressure, resulting in additional cost savings as the conveying pump can be omitted if necessary

REDUCE WASTEWATER

Flottweg wastewater decanters for processing industrial wastewater

Processing coffee generates large quantities of process wastewater with high solids contents and COD values. Since wastewater discharge is subject to strict regulations and generates additional costs, processing industrial wastewater as part of the overall process offers additional savings potential depending on the quantity. Flottweg has specifically designed special centrifuge series for this.

Industrial centrifuges continuously separate the solids from the process flows. Thanks to the high centrifugal forces, even very fine solids are removed. Depending on its origin, this treated wastewater can be recycled as service water for rinsing and cleaning purposes, which reduces the need for fresh water. In the case of wastewater discharged for disposal, decreasing the COD effluent values can have a positive effect on disposal costs.

Benefits of wastewater decanters for treating industrial and process wastewater

- Efficient and continuous separation of solids, resulting in reduced wastewater disposal costs
- 24-hour operation without monitoring
- Less space needed for high throughputs
- Easy to control and monitor thanks to continuous, automatic operation
- Closed design to reduce odor emissions

Benefits of use in industrial wastewater treatment plants

- Efficient dewatering and thickening of sewage and flotation sludge, reducing sludge disposal costs by decreasing the sludge volume
- Uniformly high dry matter content in dewatered sludge, even with fluctuating feed concentrations or volumes



QUALITY, EVEN WITH THE SMALL DETAILS

In contrast to the fully automatic production systems of large companies, smaller manufacturers are increasingly producing liquid coffee in batches. By adding hot water (or cold water, in the case of cold brew), the coffee extract is removed from the ground coffee beans batch by batch. The extract obtained in this way is usually extracted from the tank via sieve bottoms and then filtered. However, this is also more economical, as the extraction residue remaining in the tank still contains different amounts of valuable coffee extract. In this process, the extract with the residue is lost. The filter is also insufficient for processing due to the high amount of solids.

The Flottweg decanter can also increase the overall yield and product quality in such production environments: It permits the solids to be continuously separated from the coffee extract. High solids contents can be easily processed in the centrifuge. Due to the high dry matter of the discharged solid, the extract yield is significantly higher than the yield produced with the sieve tray method.

Benefits of using Flottweg decanters

- Significant increase in extract yield due to effective dewatering of coffee grounds
- This also reduces the amount of coffee grounds requiring disposal
- Separation of fine particles reduces strain on filter: decreased filtration costs
- Can be integrated into modern cold brewing processes
- Use as multi-purpose decanter for clarifying other extracts or for producing plant-based milk alternatives

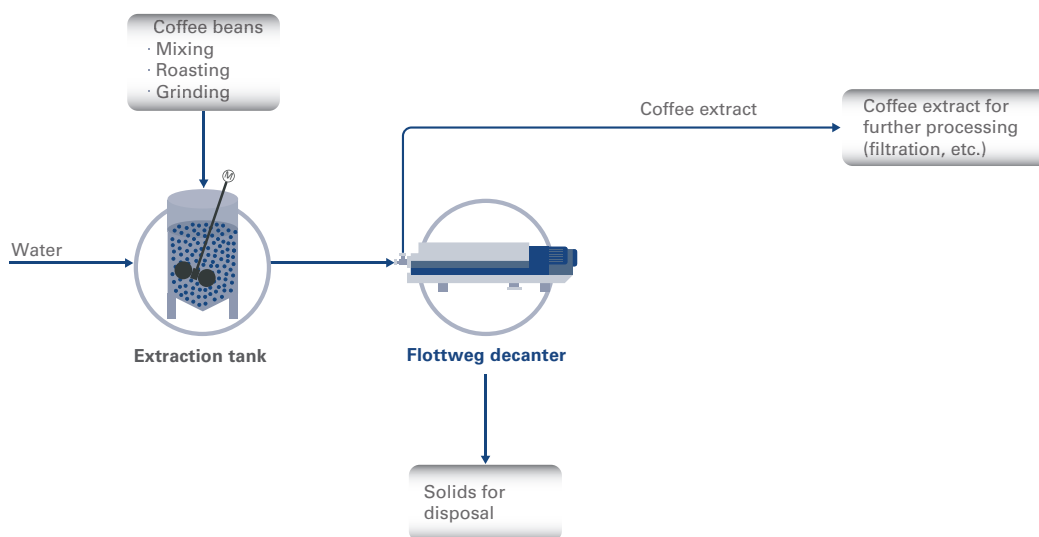



OPTIMIZING PROCESSES AND PROCEDURES

The separation technology used often has a significant impact on the operating costs of the overall process, with each customer process being individual. Some parameters can have a decisive effect on the degree of separation.

By using this technology correctly, the overall costs can be significantly reduced and profits increased. If you are in need of assistance, speak with one of our specialists and let them improve your processes!

FILTER TEST TO ASSESS THE SEPARATION EFFICIENCY OF THE SEPARATOR.

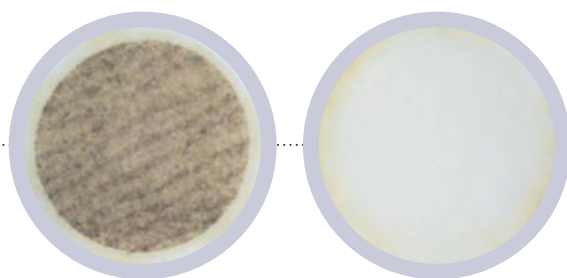

SOLIDS CONTENT OF THE COFFEE EXTRACT IN THE FLOTTWEG SEPARATOR'S FEED.

NO SOLID PARTICLES CAN BE DETECTED AFTER CLARIFICATION BY THE FLOTTWEG SEPARATOR.

SPIN TESTS TO ASSESS THE VOLUMETRIC DISTRIBUTION OF DIFFERENT EXTRACTS AND THEIR SOLID CONSISTENCY.



FLOTTWEG QUALITY AND SERVICE



Guaranteed Flottweg quality

Made in Germany. We have a clear image of quality, and we never compromise on it. Our customers often have to deal with aggressive materials. Components of Flottweg centrifuges that come into direct contact with the medium that will be processed (including the bowl, scroll, and inlet), are exclusively made from high-quality, rust and acid resistant stainless steel. This means higher strength and improved resistance.

Our machines are well-equipped, and can withstand your requirements in the long term – in extreme cases, that can mean 24 hours a day, 7 days a week. Additionally, our strict quality controls (DIN ISO 9001:2015) and the traceability of all critical components ensure product safety.



Our service – we are always there for you!

We have over 1,100 employees worldwide, in a network of over 60 sales and service stations that are available to you. We are not only striving to provide first-class advice about selecting and designing our systems. We'll be there for you whenever you need us – 7 days a week in over 100 countries all over the world.

You can plan success. In just three steps.

Would you like to turn efficient separation or clarification into your own success story?
Then get in touch with Flottweg and benefit from our 3-step roadmap:

01

We will talk to you about the separation task and the business objectives you are looking to achieve.

02

In pre-engineering, we examine your raw materials in our laboratory and carry out customer-specific tests in the Flottweg technical center or on your own premises. Here, initial product samples can already be made available to you.

03

After the design and detailed development process has taken place, you will receive a specific and individualized offer. This includes all the relevant line KPIs for realizing your customized Flottweg application.

**Make Flottweg the key player in your success:
Our sales partners are looking forward to hearing about your ideas and challenges!**





Flottweg worldwide

11
international
subsidiaries

Projects in over
100
countries

Over
50
service centers

- - Headquarters
- - Subsidiary
- - Representative





Flottweg SE

Industriestraße 6-8
84137 Vilsbiburg
Germany
Tel.: + 49 8741 301-0
Fax: + 49 8741 301-300

[Contact form](#)

mail@flottweg.com

www.flottweg.com

